



# 刀霸銑刀

捨棄式刀頭最小尺寸達10mm，有直柄型、鎖牙型 2種選擇。  
刀片擁有高進給、高耐磨特性

## Features

### ▶ A型銑刀片

- 超微粒刀片
- 高正角刀片
- 肩銑直角度佳

### ▶ C型清角刀片

- 超微粒刀片
- 特殊切削角設計，適合精修3D模具
- C型刀片可作插銑加工

### ▶ R型刀片

- 特殊刀片角度設計
- 超微粒刀片
- 特殊角度設計，適合3D模具精修
- R型刀片可作插銑加工

### ▶ 十六面刀霸

- 適合M / C面銑加工
- 刀具成本低
- 超強刃口設計，進給可達0.5mm / tooth
- 刀片表面有序號，辨認快速



4

刀霸系列

斜向進刀

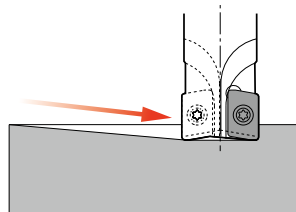

螺旋下刀

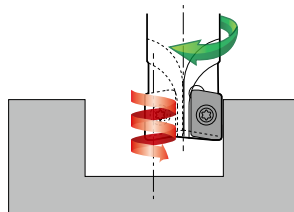

# 刀霸銑刀系統

## A 型銑刀

Ø10-Ø25 99802-BC..A..  
 Ø20 & Ø25 99522..  
 Ø10-Ø25 99802-M..A..  
 99805-M..A..

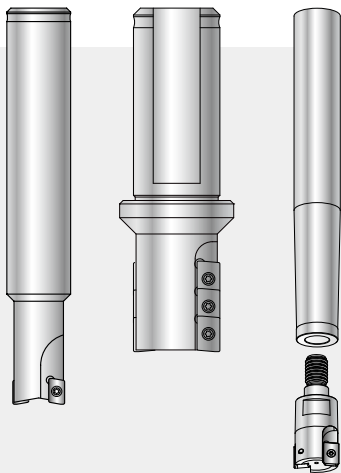

A9MT06...  
 A9MT10...

## C 型清角刀

Ø12-Ø25 99802-BC..C..  
 Ø10-Ø26 99802-M..C..  
 99805-M..C..

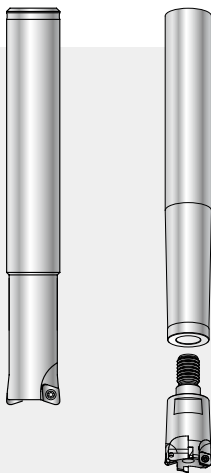

C9MT05...

## R 型銑刀

Ø16-Ø35 99802-BC..R..  
 Ø50-Ø100 99802-MC..R..  
 Ø16-Ø35 99802-M..R..

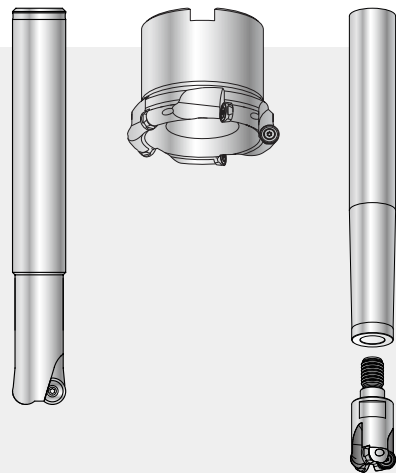

R9MT08...

## 十六面刀霸銑刀

Ø32 99542-032 (粗銑)  
 Ø50-Ø125 99542-... (CW)  
 99542-... L (CCW)  
 Ø63, Ø80 and Ø100 99543-063  
 99543-080  
 99543-100 (高速)

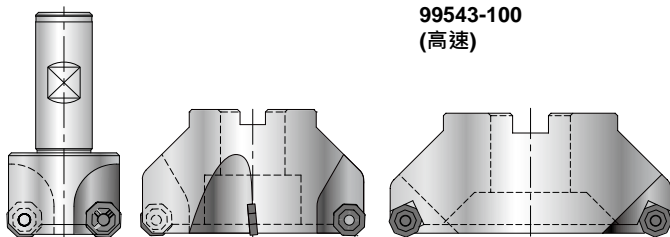

N9GJ11T3F2-0

## 特輕鋁合金銑刀

Ø80-Ø315mm 99511-...

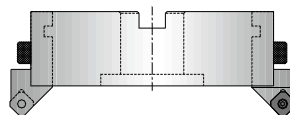

N9MT11T3HR300 鏡面加工  
 N9GJ11T3F2 鏡面加工

## E 銑刀

Ø14-Ø25mm 99617-...



N9FX... 高速鋼加工

4

刀霸系列

# A型銑刀

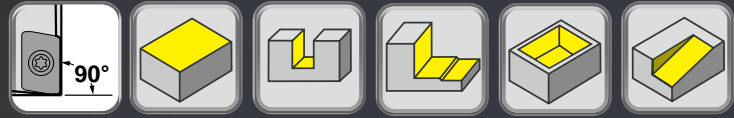

特色:

- 高強度設計，高正角切削
- 肩銑直角度佳

## 刀桿

### ▶ 直柄型

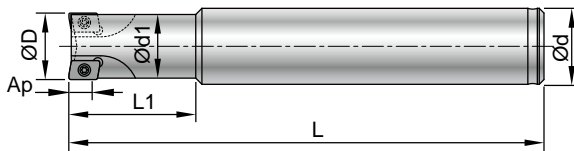
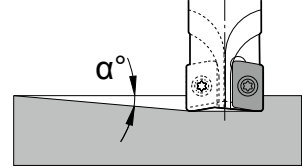

Part No.	Type	ØD	No. of teeth	Ød h6	Ød1	α°	Ap	L1	L	刀片類型
99802-BC10-10A06	BC10-10A06-100	10	2	10	9.8	5.0	5	40	100	A9...0602...
99802-BC12-10A06	BC12-10A06-80	10	2	12	9.8	5.0	5	20	80	
99802-BC12-11A06	BC12-11A06-80	11	2	12	10.8	4.5	5	22	80	
99802-BC12-12A06	BC12-12A06-80	12	2	12	11.4	4.0	5	24	80	
99802-BC16-13A06	BC16-13A06-100	13	2	16	12.4	3.5	5	26	100	
99802-BC16-14A06	BC16-14A06-100	14	2	16	13.4	3.0	5	28	100	
99802-BC16-15A06	BC16-15A06-100	15	3	16	14.4	2.5	5	30	100	
99802-BC16-16A06	BC16-16A06-100	16	3	16	15.4	2.0	5	32	100	A9...1035...
99802-BC16-16A10	BC16-16A10-100	16	2	16	14.5	2.5	9	32	100	
99802-BC20-20A10	BC20-20A10-120	20	3	20	18.5	2.0	9	40	120	
99802-BC25-25A10	BC25-25A10-150	25	3	25	23.5	1.3	9	50	150	

### ▶ 密齒側銑刀

- 強力! 長刃銑刀。BT40專用

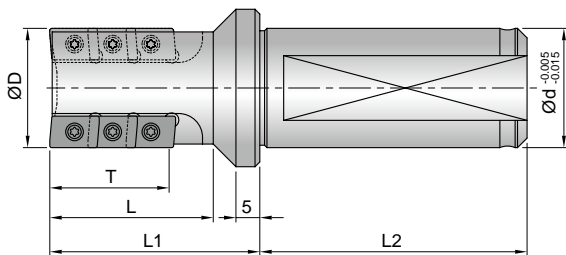

Part No.	Type	ØD	No. of teeth	Ød	T	L	L1	L2	刀片類型
99522-20	SB20-EM20x3T	20	3	20	18	24.5	35	50	A9..1035...
99522-25	SB25-EM25x6T	25	6	25	25	34.25	44	56	

4

刀霸系列

# A型銑刀

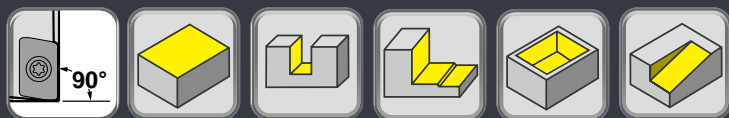

## 刀桿

### 鎖牙型

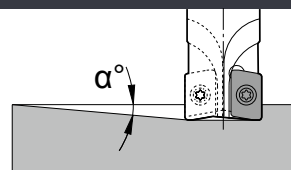
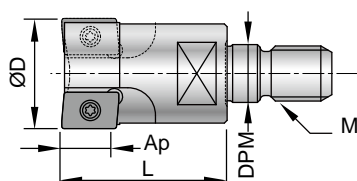

Part No.	Type	ØD	No. of teeth	α°	Ap	L	M	DPM	刀片類型
99805-M05-10A06	M05-10A06	10	2	5.0	5	13	M5xP0.8	5.5	A9...0602...
99805-M05-11A06	M05-11A06	11	2	4.5	5	13	M5xP0.8	5.5	
99805-M06-12A06	M06-12A06	12	2	4.0	5	13	M6xP1.0	6.5	
99805-M06-13A06	M06-13A06	13	2	3.5	5	13	M6xP1.0	6.5	
99805-M08-14A06	M08-14A06	14	2	3.0	5	13	M8xP1.25	8.5	
99805-M08-15A06	M08-15A06	15	3	2.5	5	15	M8xP1.25	8.5	
99805-M08-16A06	M08-16A06	16	3	2.0	5	15	M8xP1.25	8.5	
99805-M08-17A06	M08-17A06	17	3	1.5	5	15	M8xP1.25	8.5	
99802-M08-16A10	M08-16A10	16	2	2.5	9	25	M8xP1.25	8.5	A9...1035...
99802-M10-20A10	M10-20A10	20	3	2.0	9	30	M10xP1.5	10.5	
99802-M12-25A10-3T	M12-25A10-3T	25	3	1.3	9	35	M12xP1.75	12.5	
99805-M12-25A10	M12-25A10	25	3	1.3	9	20	M12xP1.75	12.5	

\* 延長桿請詳見6-191頁

# A型銑刀



## 特色:

- 超微粒刀片，實現高精度切削。
- 良好的切削性能和高強度切削刃，可產生極佳的90°肩銑。

## 刀片

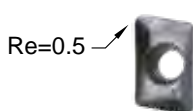

### A9MT060205-NC5072

- 高強度設計，銑削安定
- 高正角切削，高移除率
- P40底材，適合鋼鐵

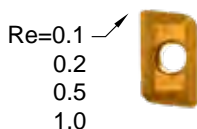

### A9GT0602...H-NC9031

- 高正角切削，適合非鐵金屬加工
- K20F底材，適合鋁合金，銅合金，非鐵金屬

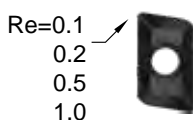

### A9GT0602...H-NC2033

- 銳利的高正角切削，適合精修
- 表面加工優異
- K20F底材，適合鋼鐵

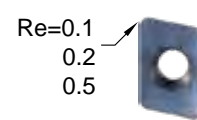

### A9GT0602...U-NC2032

- U型刀片經過全磨削，減少切削時的切削阻力，是長柄刀具的最佳選擇。
- K20F底材，適合鋼鐵

刀片尺寸	Parts No.	鍍層	材質	Dimensions					螺絲 / 扳手		
				L	W	S	Re	Ap			
06	A9MT060205	NC5072	TiAlN	P40		6.5	4	2.45	0.5	5	NS-18037 0.6Nm / NK-T6
	A9GT060201H	NC2033	TiAlN	K20F		6.5	4	2.45	0.1	5	
		NC9031	TiN			6.5	4	2.45	0.2	5	
	A9GT060202H	NC2033	TiAlN	K20F		6.5	4	2.45	0.5	5	
		NC9031	TiN			6.5	4	2.45	1.0	5	
	A9GT060205H	NC2033	TiAlN	K20F		6.5	4	2.45	0.1	5	
		NC9031	TiN						0.2	5	
	A9GT060210H	NC2033	TiAlN	K20F		6.5	4	2.45	1.0	5	
<b>NEW</b> A9GT060201U	NC2032	TiAlN	K20F	6.5	4	2.45	0.1	5			
<b>NEW</b> A9GT060202U	NC2032	TiAlN					0.2	5			
<b>NEW</b> A9GT060205U	NC2032	TiAlN					0.5	5			

4

刀霸系列

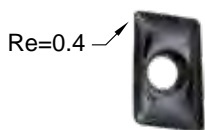

### A9MT1035-NC2032

- 高強度設計，銑削安定
- 高正角切削，高移除率
- K20F底材，適合碳鋼、合金鋼

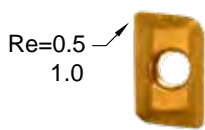

### A9GT103510H-NC9031

- 高正角切削，適合非鐵金屬加工
- K20F底材，適合鋁合金，銅合金，非鐵金屬

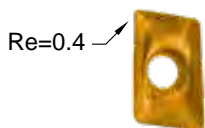

### A9MT1035-NC40

- 高強度設計，銑削安定
- 高正角切削，高移除率
- P40底材，適合不鏽鋼

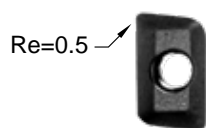

### A9GT103505H-NC2032

- 銳利的高正角切削，適合精修
- 表面加工優異
- K20F底材，適合鋼鐵

刀片尺寸	Parts No.	鍍層	材質	Dimensions					螺絲 / 扳手	
				L	W	S	Re	Ap		
10	A9MT1035-NC2032	TiAlN	K20F		10	6.6	3.5	0.4	9	NS-25060 0.9Nm / NK-T7
	<b>NEW</b> A9MT1035-NC40	TiN	P40		10	6.6	3.5	0.4	9	
	A9GT103505H-NC9031	TiN	K20F		10	6.6	3.5	0.5	9	
	<b>NEW</b> A9GT103505H-NC2032	TiAlN	K20F		10	6.6	3.5	0.5	9	
	<b>NEW</b> A9GT103510H-NC9031	TiN	K20F		10	6.6	3.5	1.0	9	

# A型銑刀

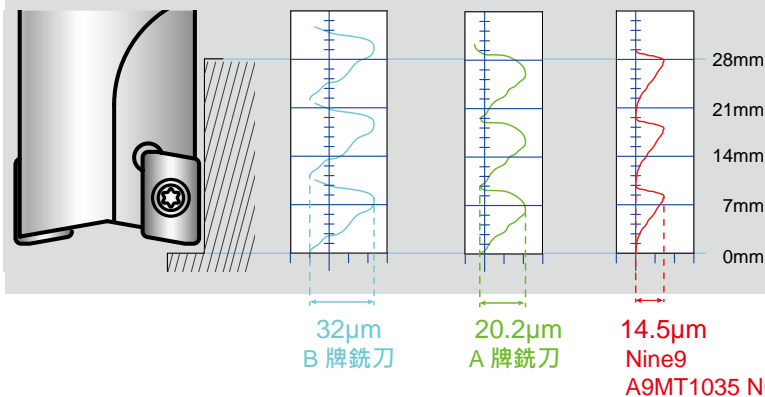

## 表面粗糙度比較

- Nine9 A型銑刀可獲得更好的表面光潔度。

## 切削資料

- 開槽加工需降低 30% 進給速度
- 傾斜角度應小於 $\alpha^\circ$

### ▶ 刀片尺寸: 6.5mm (刀桿尺寸: Ø10~Ø17mm)

工件材質	代碼 (JIS)	刀片材種	Vc (m/min)	fz (mm/tooth)	Ap(mm)	Ae(mm)	Ae(mm)
碳鋼	P5	NC5072	80~150	0.03~0.07	1.5	4	1.5
		NC2033					
低合金鋼 C ≤ 0.3%	SCM440	NC5072	80~150	0.03~0.07	1.5	4	1
		NC2033					
		NC2032					
高合金鋼 C > 0.3%	SKD11	NC5072	60~120	0.03~0.07	1	2.5	1
		NC2033					
		NC2032					
不鏽鋼	SUS304	NC5072	60~120	0.01~0.05	0.5	2	1
		NC2033					
鑄鐵	FC25	NC5072	60~120	0.03~0.07	1	2.5	1
		NC2033					
可鍛鑄鐵·灰鑄鐵		NC5072	100~150	0.03~0.07	1.5	4	1.5
		NC2033					
鋁·鋁合金	A6061	NC9031	200~500	0.03~0.07	2	4	2

### ▶ 刀片尺寸: 10mm (刀桿尺寸: Ø16~Ø25mm)

工件材質	代碼 (JIS)	刀片材種	Vc (m/min)	fz (mm/tooth)	Ap(mm)	Ae(mm)	Ae(mm)
碳鋼	P5	NC2032	150~250	0.08~0.15	3	8	3
低合金鋼 C ≤ 0.3%	SCM440	NC2032	150~250	0.08~0.15	3	8	2
高合金鋼 C > 0.3%	SKD11	NC2032	120~200	0.08~0.15	2	4	2
不鏽鋼	SUS304	NC2032	80~120	0.04~0.08	1	4	2
		NC40					
鑄鐵	FC25	NC2032	120~200	0.08~0.12	2	5	2
可鍛鑄鐵·灰鑄鐵		NC2032	100~150	0.06~0.10	3	8	3
鋁·鋁合金	A6061	NC9031	200~500	0.03~0.07	5	8	3

4

刀霸系列